

SECURITRON SOLENOID CABINET LOCK MODEL SCL-12 and SCL-24 INSTALLATION AND OPERATING INSTRUCTIONS

1. DESCRIPTION

The SCL is a solenoid operated cabinet lock which is installed and used for access control applications such as pharmaceutical storage lockers, jewelry cases, drawers and other numerous types of cabinets and storage devices. The lock is available in 12VDC or 24VDC and is a fail secure device only. Relocking occurs automatically on closure of the door. Holding force is 600 pounds (275 Kg) which is generally stronger than the cabinet or case being locked.

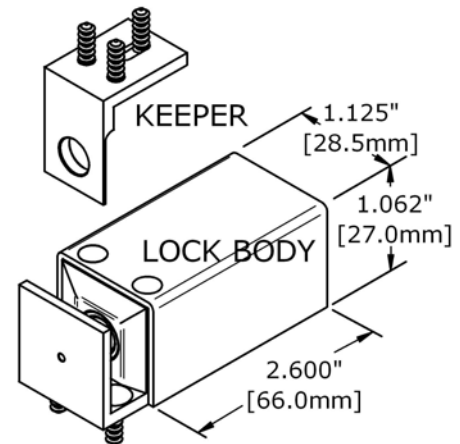

2. PHYSICAL INSTALLATION

The SCL is adaptable for controlling a variety of doors and drawers. The principle is to attach the lock body to the stationary frame and then attach the keeper to the movable portion such as a door or drawer. Fasteners are supplied which can be applied in both metal and wood. *Note: The weakest point of an SCL installation is the strength of the keeper and the mounting hardware.* If the application expects to utilize the full force of the lock make sure the hardware does not conflict with the security.

One of the unique features of the SCL-24 is that the keeper can enter the lock body from any of three directions as shown in Figure 1. This allows efficient mounting on the three types of applications, such as a swing type door or a pull-out type and sliding type door. Figure 4 and Figure 5, located at the end of the instruction manual illustrates positioning of the applications types.

Note: For a sliding door, some special work is necessary to recess the lock body (typically through the use of a bracket) so that the door is able to close to the flush position.

Note: When mounting the keeper, one of the holes is elongated. The first screw should go in the elongated hole and then the keeper can be precisely positioned with respect to the opening in the lock body by experimentally closing the drawer or cabinet. When you are satisfied with the position, the other screws may be installed to complete the mounting of the keeper.

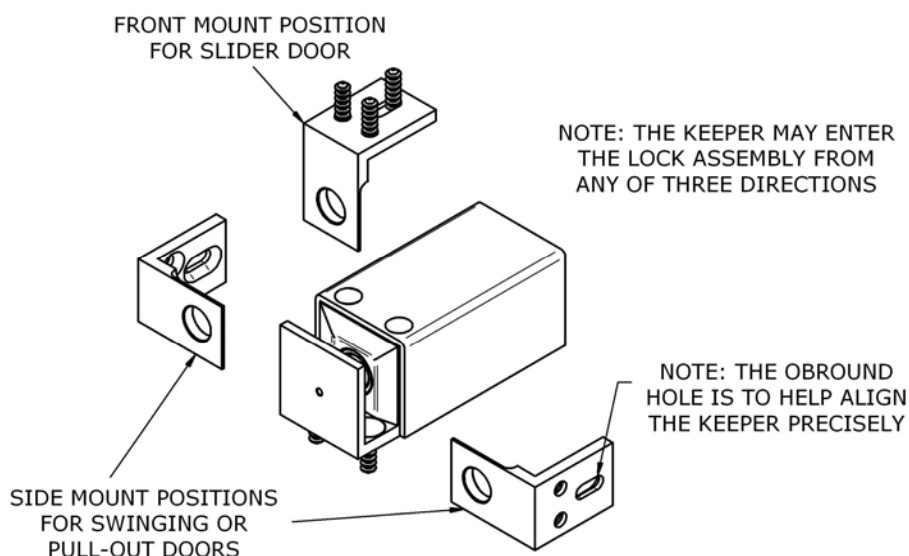

Figure 1

2.1 MOUNTING ON A NEW FIXTURE

Cabinets being manufactured are able to be prepared with the proper mounting holes and locations using the diagrams illustrated in the back of the manual.

2.2 RETROFIT MOUNTING

When retrofit mounting is being performed on an existing cabinet, the measurements can not be made from the inside of the cabinet when the door is shut. It is recommended that the installer purchase a Model SCLT installation tool to simplify the installation; illustrated to the right in Figure 2. The tool is for placing into the solenoid assembly. Using the dowel punch pin in the tool, it locates the proper position for the center oval latch mounting hole.

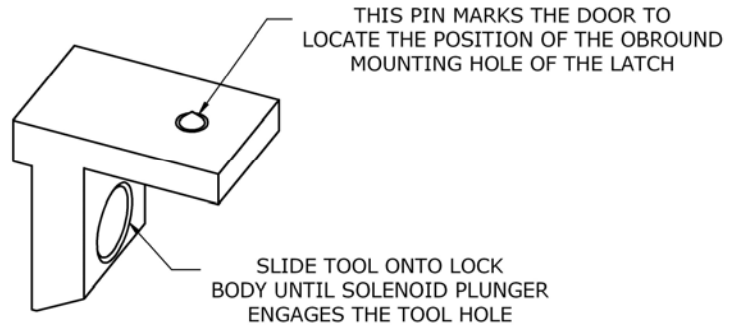

Figure 2

2.3 SWING DOOR MOUNTING

The lock body mounts in the orientation shown in Figure 2. First establish a line on the header above the door which represents the close “line” of the door. This is set by the position of the door stop. Measure back 7/16” [11mm] from this line and draw a second line. This is the backset for the front screw mounting of the lock body. Measure in 1” [25.4mm] from the cabinet wall and punch the location for the front screw. The location of the rear screw should be placed 21/32” [16.7mm] back from the front. Drill pilot holes and mount the lock body.

Note: Before mounting the keeper, pull the lock body wires out of the cabinet to where you can apply power. This must be done before the keeper is mounted because if you mount the keeper and shut the cabinet without being able to power the unit, you will not be able to open the cabinet door and the unit locks when not powered.

To mount the keeper, insert the SCLT tool into the lock body so that the punch pin faces the door. Close the door or drawer slowly until closed. Press firmly to produce a mark on the door. Drill a pilot hole into the mark and mount a screw into the oval hole of the keeper and slightly tighten. Experiment with the final mounting position by testing the door locking and releasing. When you are satisfied, install the remaining two screws into the keeper holes marking and drilling the pilot holes followed by the screws. Tighten all screws and re-test the installation.

3. OPERATION AND WIRING

The unit Operational specifications are listed below. The unit indicates the voltage on the solenoid. Be aware of the unit voltage prior to installation and electrical operation.

<p><u>Model SCL-12:</u></p> <p>Operation: Intermittent Duty Holding Force: 600 lbs. (272 Kg) Dimensions: 2.63” [67mm] Long 1.06” [27mm] Tall 1.13” [29mm] Deep Voltage: 12 Volts DC (10.0 to14.0 VDC) Current: 400mA @ 12VDC Lead Color: White</p>	<p><u>Model SCL-24:</u></p> <p>Operation: Intermittent Duty Holding Force: 600 lbs. (272 Kg) Dimensions: 2.63” [67mm] Long 1.06” [27mm] Tall 1.13” [29mm] Deep Voltage: 24 Volts DC (20.0 to 28.0 VDC) Current: 200mA @ 24VDC Lead Color: Black</p>
--	---

The wiring diagram below in Figure 3 illustrates the correct hook up for the solenoid operation. The power does not need to be regulated. Use of a transformer + bridge rectifier is acceptable. *Note: The SCL operates on an intermittent duty cycle only. Power should be applied for brief periods only to gain access to the cabinet. Continuous power applied to the unit will overheat the solenoid and may damage the solenoid or the operational characteristics.* Installing of the MOV is to absorb inductive kickback from the solenoid coil. If not used, it could shorten the life of a control switching relay or transistor.

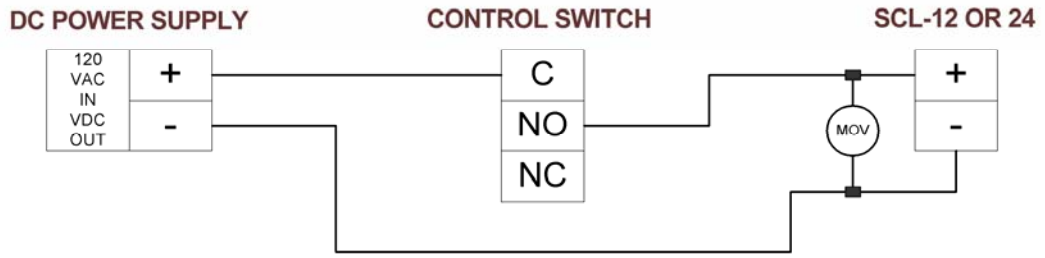

Figure 3

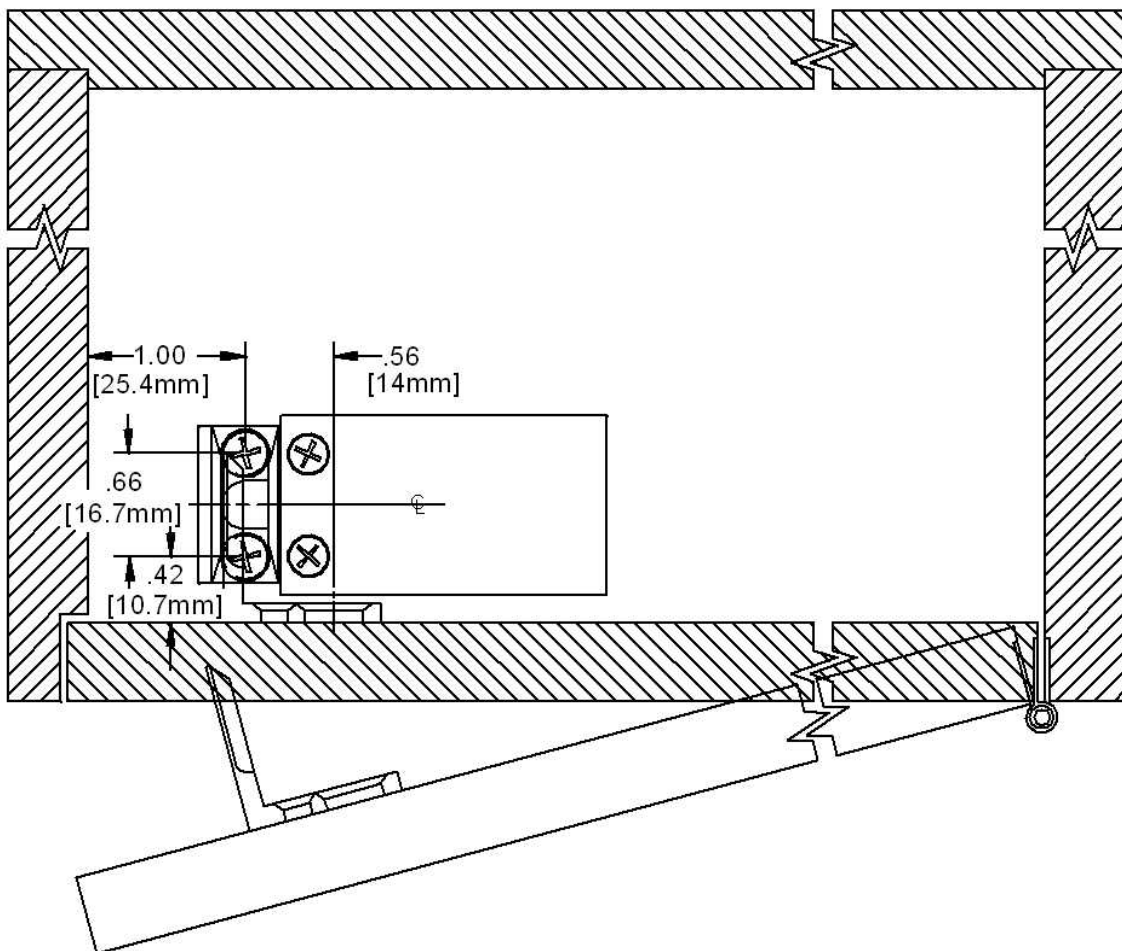
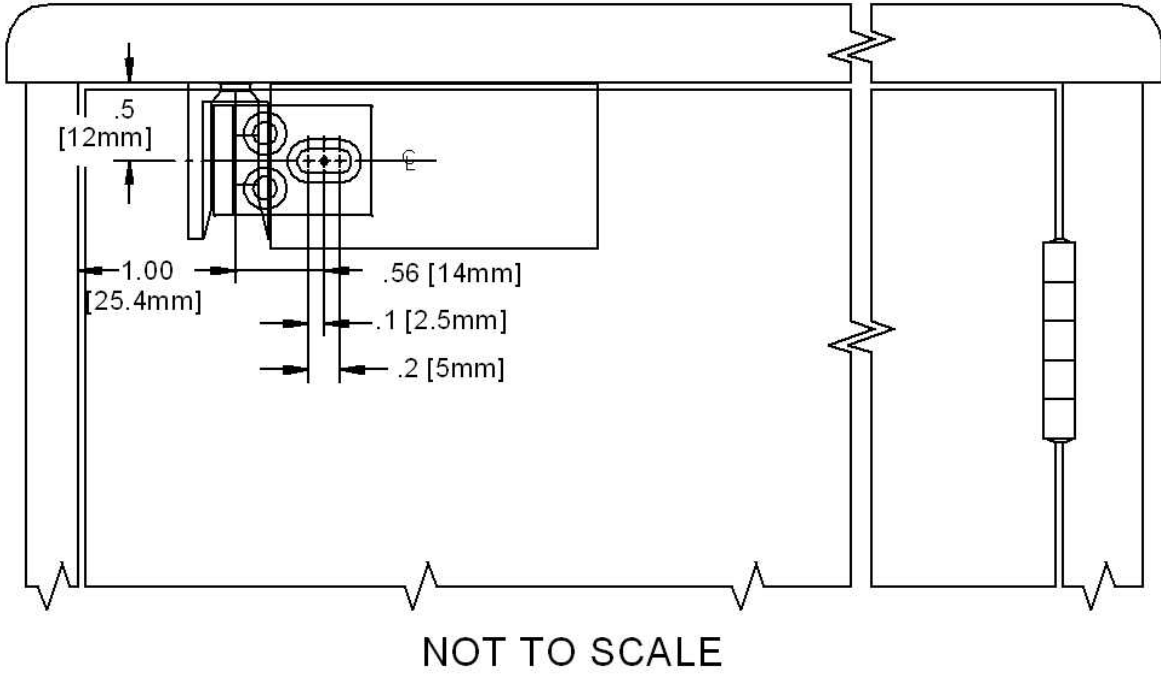
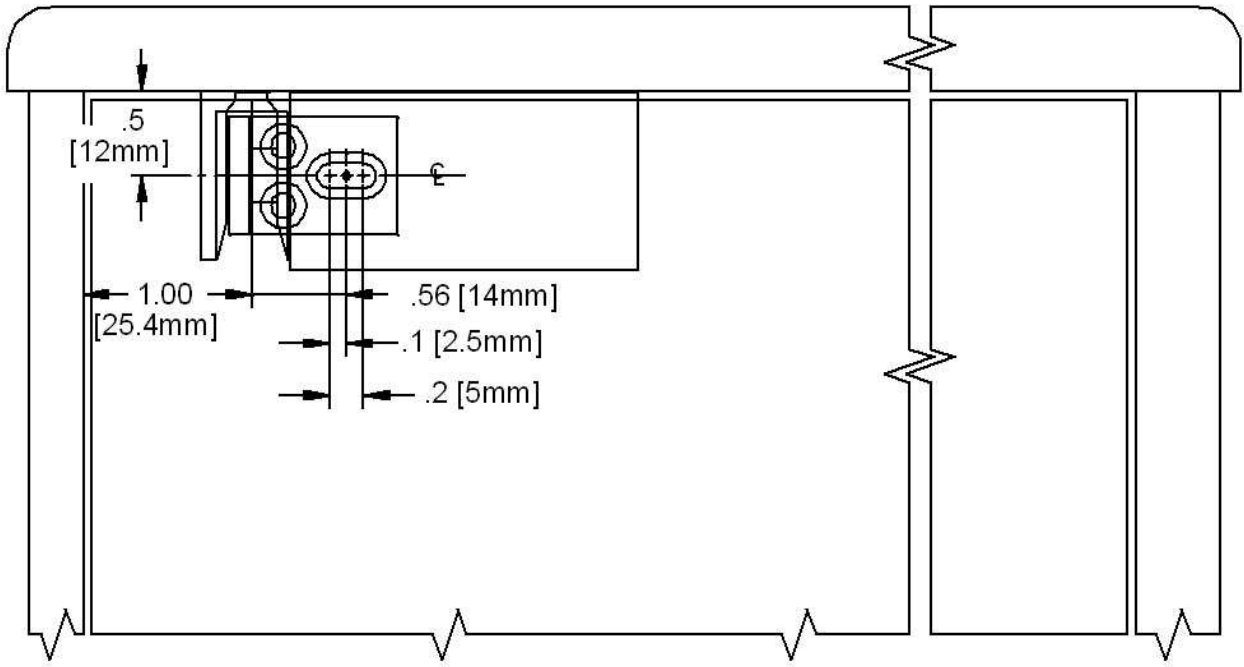

Figure 4

PREPARATION FOR SWINGING DOOR INSTALLATION



NOT TO SCALE

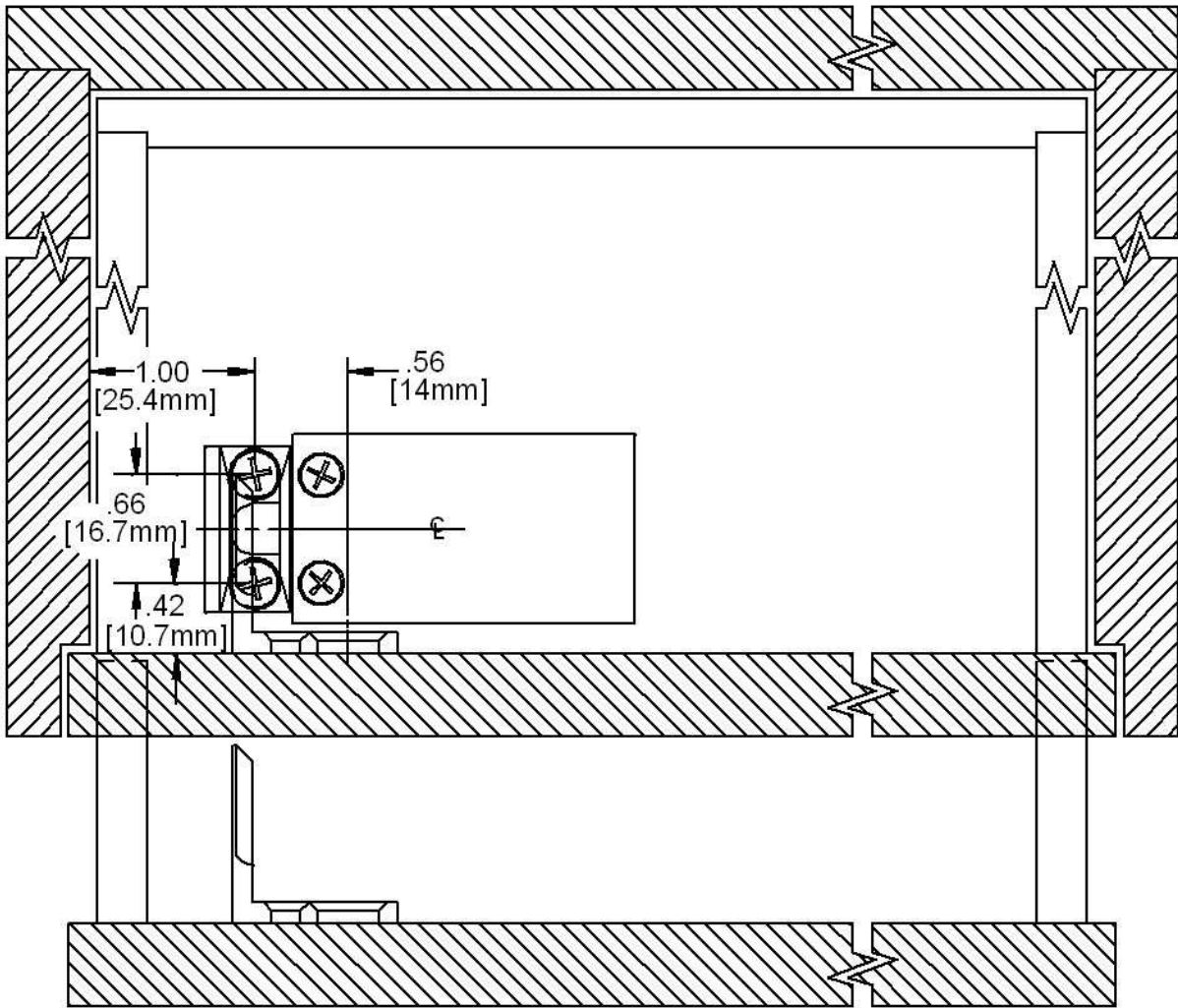

Figure 5

PREPARATION FOR PULL OUT DRAWER INSTALLATION