

SECURITRON ALUMINUM SPACER BRACKET MODELS ASB-32, ASB-62 AND ASB-82 INSTALLATION INSTRUCTIONS

1. PRODUCT DESCRIPTION

The **ASB** Aluminum Spacer Bracket is a 1/2" [12.7mm] thick anodized aluminum spacer bracket with three (3) individual designs each for the Models M32, M62 or M82 Magnalocks. Installations that contain aluminum door frames with or without blade stops may require this type of special spacer/structural type bracket. The purpose of the ASB bracket is to improve frame mounting strength, Magnalock/Strike clearances, alignments and ease of the installation. The brackets are available for all standard mount M32, M62 and M82 Magnalock models.

2. PRODUCT OVERVIEW

All three (3) ASB brackets are separately available in clear or black anodized finishes. The illustration below in **Figure 1** indicates the three bracket model types. Along with these instructions, each model type contains one (1) model type bracket and the individually related hardware pack. Upon unpacking this product, an inventory should be made to ensure that the required bracket and hardware have been included.

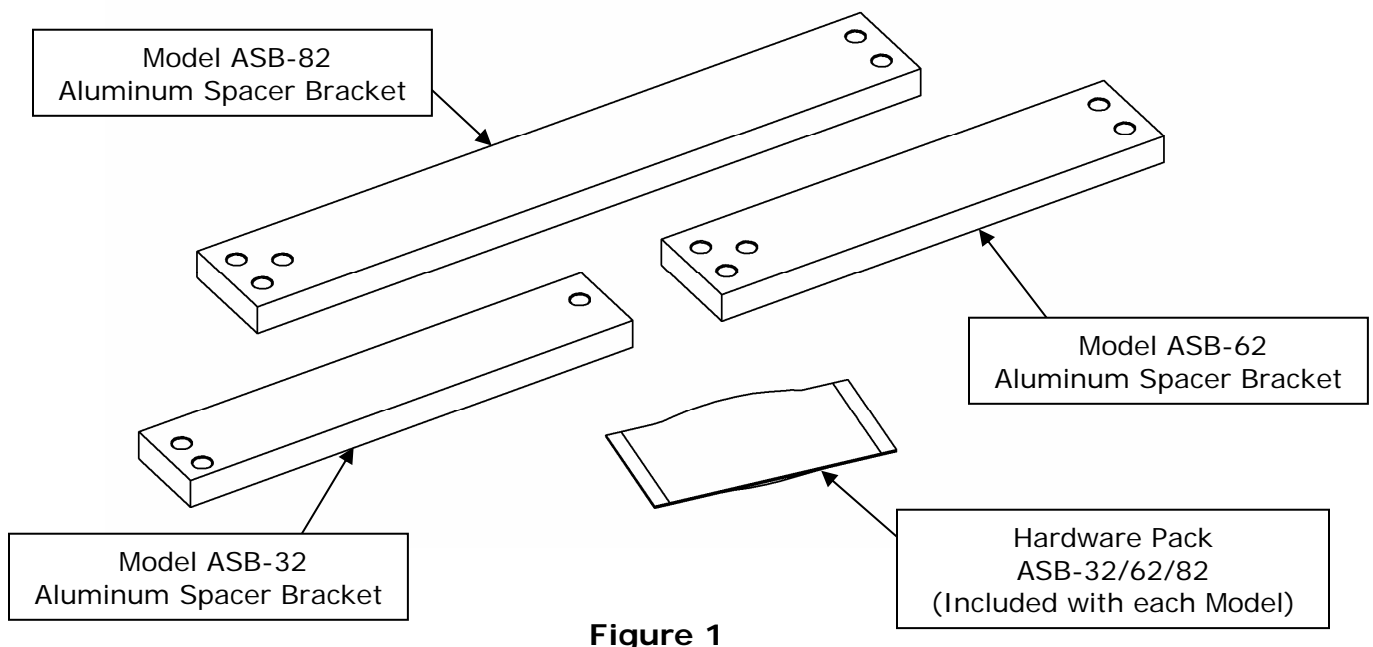

Figure 1

3. RECOMMENDED TOOLS

Power Drill
Center Punch

Drill Bits: 3/8" [9.5mm]
3/16" Hex Wrench

1/2" Wrench or Adjustable

4. ALUMINUM DOOR STRIKE ARMATURE MOUNTING

When mounting the strike, determine the proper location in relationship to the Magnalock prior to proceeding. Aluminum frame doors vary depending on the top rail (shoe) size and the internal structural design. When a sex bolt is not feasible, a special 5/16-18 threaded blind nut may be installed using the same techniques detailed in the Magnalock installation manual. **Figure 2** illustrates the blind nut tool assembly before and after collapsing.

NOTE: OFFSET STRIKES MAY BE NECESSARY FOR FRAME STRUCTURE ALIGNMENT

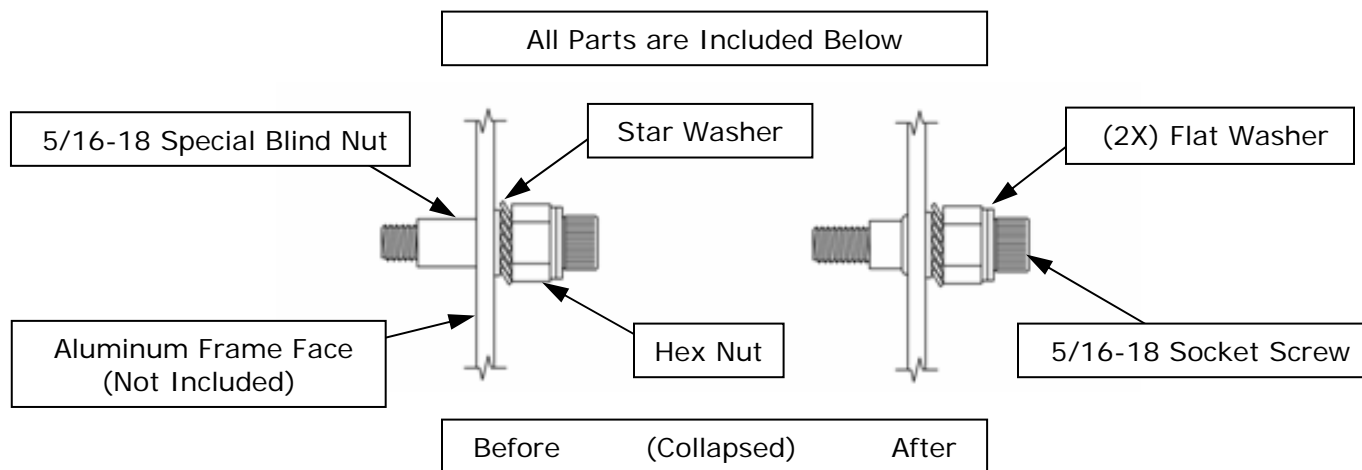

Figure 2

5. ALUMINUM FRAME MAGNALOCK MOUNTING

Mounting the ASB aluminum spacer bracket onto an aluminum frame header requires use of the blind nuts and 1/4-20 socket head cap mounting screws. Proper use of the blind nuts and mounting screws ensure a safe and secure mounting of the Magnalock reducing the possibility of the Magnalock becoming loose during regular use. **Figure 3** illustrates a visual concept of the parts that will be applied to secure the ASB bracket in an M62 Magnalock installation. The amount of blind nuts and the length of the screws vary depending on the model Magnalock being installed.

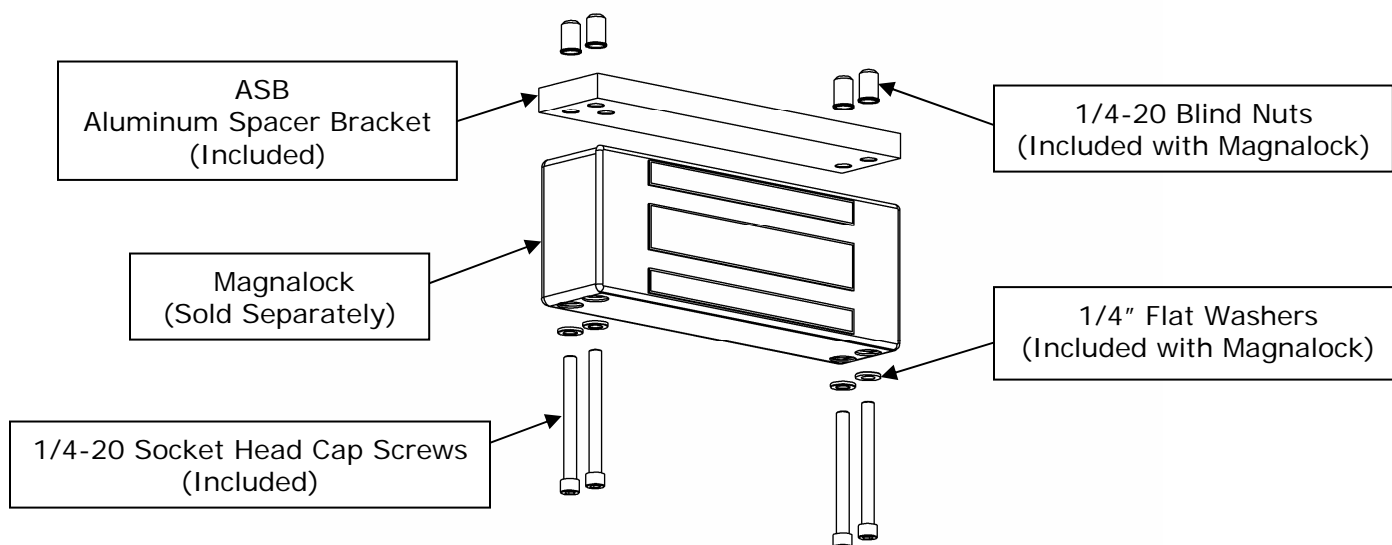

Figure 3

While installing the ASB aluminum spacer bracket onto an aluminum frame, follow the Step-By-Step procedures listed below:

- To position the spacer bracket in the desired location on the frame, use the Magnalock template provided and mark the cable access hole and the mounting holes where and the blind nuts will be located.
- Drill the marked mounting hole locations in the frame using a 3/8" [9.5mm] drill.
- Drill the marked hole for the cable access into the frame as indicated on the Magnalock template provided.
- Using the blind nut installation tool and the installation procedures provided in the Magnalock package, properly mount the blind nuts.
- Position the Magnalock and the cable onto the ASB bracket and mount the Magnalock and bracket assembly onto the frame and securely tighten using the socket head cap screws provided in the ASB hardware package and the washers provided in the Magnalock hardware package.