

## MODEL IK, IKM INSTALLATION TOOL KIT INSTRUCTIONS FOR USE

### 1. DESCRIPTION

The IK contains tools that will improve the speed and quality of model 62 and 32 Magnalock installations. It also includes additional fasteners and a Tips and Techniques Installation Video. The IKM is the export version which includes metric fasteners.

### 2. DRILL GUIDE

The drill guide is the gold colored angle piece. This allows drilling more rapid and accurate pilot holes for mounting the magnet and strike plate on **outswinging doors**. It replaces the paper template provided with the lock. The holes in the guide are sized for use with a 1/8" drill bit and the guide includes hardened steel bushings so that it will last for many Magnalock installations.

#### 2.1 POSITIONING THE GUIDE

The first point to notice about the guide is that it has **two sets of holes**: for the 62 and 32 Magnalock. The six 32 Magnalock holes are surrounded by a **silver colored ring**. The eight 62 holes are "plain". Next, the guide must be placed against the door and frame (with the door closed). Figure 1 shows the concept of positioning the drill guide for horizontal and vertical mounting. Note that the 3 "in line" holes are always for the strike plate and it is this set of holes that must be positioned on the door. Note also that in the drawing, the guide has been moved in from the corner somewhat. This is to permit easy drilling of the holes nearest the corner. This distance that the guide should be moved in from the corner will depend on the type of drill you will be using. You can set this distance by simply positioning the drill against the frame.

**FIG. 1: POSITIONING THE DRILL GUIDE FOR HORIZONTAL AND VERTICAL MOUNTING**

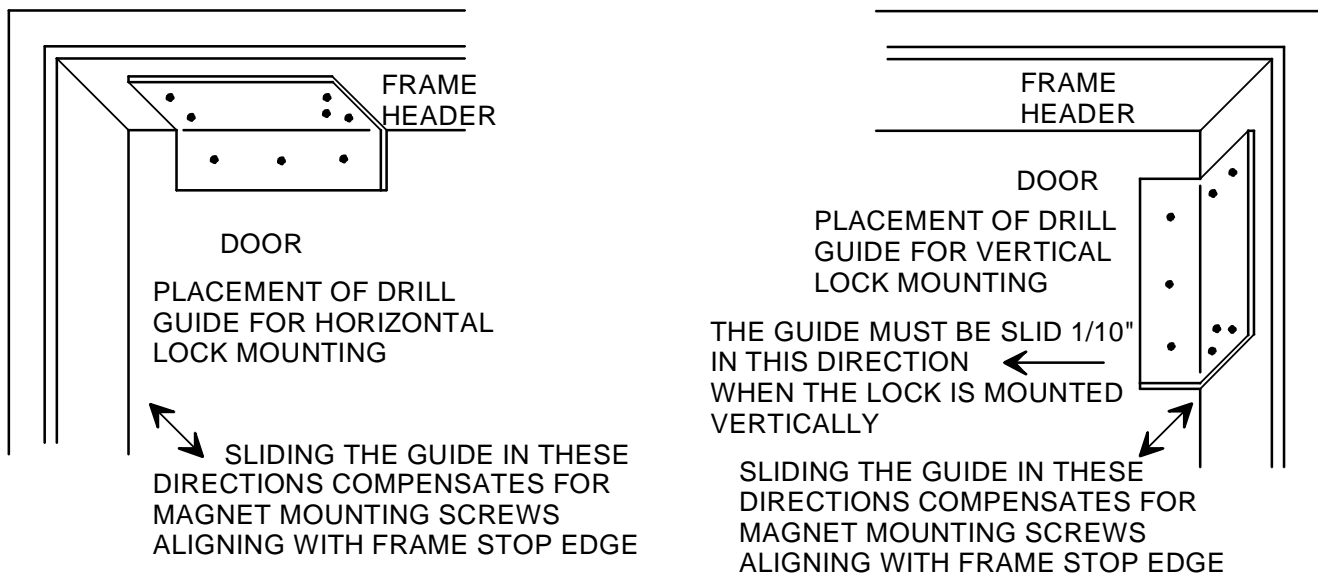

The drawing shows an "ideal" door frame because the door stop is wide enough to fully mount the magnet body. This will not always be the case and you should be prepared to employ accessory brackets. See the Magnalock instruction manual for descriptions of these brackets. One problem that brackets cannot solve is if the mounting screws of the magnet body fall on an edge in the frame or stop. This can be compensated for by varying the number of rubber washers that stand off the strike plate from the door. The stand off that is set by positioning the drill guide as shown in Figure 1 is 1/4" (6MM) which is the thickness of two rubber washers. Magnalocks are delivered with three rubber washers and extras are supplied with the kit so you can slide the guide farther away from the door and compensate with extra rubber washers. You can also drop down to one rubber washer by moving the guide 1/8" (3MM) closer to the door. To accomplish this, obviously the door must be opened slightly. Note also that when you're using the model 62, it is possible to mount the product with only two magnet mounting screws (at opposite ends of the magnet). This is not ideal as it sacrifices some rigidity, but two screws mounted into blind nuts are of adequate strength.

Above we've discussed a reason for sliding the guide **towards and away** from the door. For **vertical mounting**, the guide must be slid **parallel** to the door to move the top of the strike a little farther away from the top of the magnet. The guide sets this spacing at 1/10" (2.5MM) which is appropriate for a horizontal mount. This spacing insures that the top of the strike will not scrape against the door frame header. If the magnet is to be mounted vertically as shown in Figure 1, the guide must be slid away 1/10" (2.5MM) parallel to the door so that the strike top will now be 2/10" (5MM) away from the top of the magnet. The reason for this is that with a vertical mount, the door closes on an arc and since the strike stands out from the door, it will scrape against the frame stop unless this extra separation is achieved.

## 2.2 DRILLING THE HOLES

When drilling the holes it is important to realize that **the only critical holes are the magnet mounting holes**. The strike mounting holes include two roll pins that fit very loosely in their holes. Therefore be most careful when you are drilling the magnet mounting holes (two in the case of the model 32; four in the case of the model 62).

If no sliding of the guide is necessary as described above, all of the holes may be drilled at once. A 1/8" drill bit (furnished) is needed and an excellent technique is to begin with the central strike mounting screw hole which should be drilled completely through the door. Then place a second 1/8" drill bit (or rod) into this hole to stabilize the guide for the drilling of the other holes. All other holes do not go through the door but should be drilled to a depth of roughly 1 1/4" (32MM).

If the guide must be slid, only one of its surfaces will be against the door/frame at a time. Therefore the drilling of the strike and magnet mounting holes must be split into two different operations. The guide is slid and the holes are drilled for the repositioned magnet or strike. It is then slid back to drill the holes for the remaining component.

Once the 1/8" pilot holes are drilled, they should be enlarged to 3/8" or 1/2" depending on the hole type. Drill bits of these two sizes are furnished and the paper template delivered with the Magnalock shows the required hole sizes. For best accuracy on the critical magnet mounting holes, use an intermediate 5/16" drilling step.

Note that the furnished drill bits are of different types which have been selected for optimum performance. Understanding the drill bit types is helpful when they require replacement. The gold colored 1/8" and 3/8" bits are **cobalt** which is a strong and long lasting drill bit type particularly good in steel and aluminum. A second 3/8" bit is gray in color and is **carbide** for drilling into concrete filled headers. The 1/2" bit is a high speed steel bit which is less durable but it is extra long so it is easy to keep straight when you drill through the door. The 1/2" drill is used only for one hole and is not readily available in cobalt with the extra length.

## 3. BLIND NUT COLLAPSING TOOL

The second important tool in the kit is the blind nut collapsing tool (see drawing to the right). This tool allows faster installation of the blind nuts than does the small tool furnished with each Magnalock. To use this tool, first free the handles by removing the bent metal wrench that holds them together. The wrench is used for replacing the threaded stud which carries the blind nut and as Magnalocks only use one thread pitch, the wrench is not needed. Note however that the stop ring does unscrew for removal (this is part of the procedure of changing the threaded stud). It can easily become loose. You turn it counterclockwise to tighten it and clockwise to remove it.

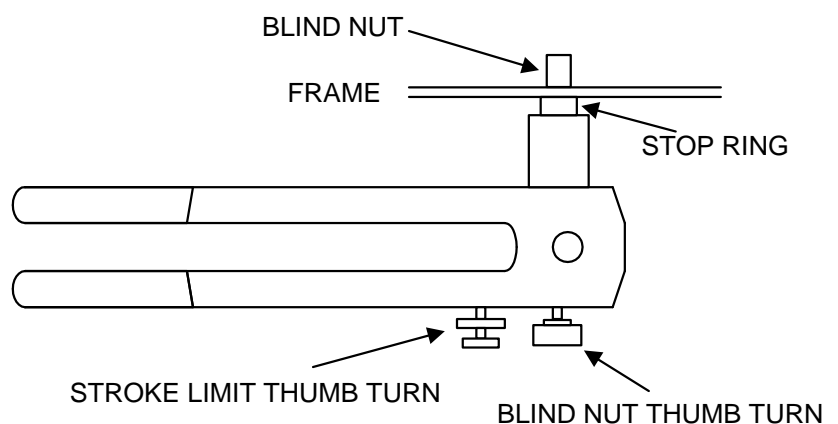

Next note that the stroke limit thumb turn and connecting shaft is present to stop the handles from coming too close when you squeeze the tool and therefore injuring your fingers. It requires no adjustment. Make sure that the handles open and close easily and then thread a

blind nut onto the threaded stud with the flange facing the tool and the beveled end facing the frame. How far down the stud, the nut will go depends on how much you allow the handles to open. **Open them about 1/3 of their maximum** and thread the blind nut down on the stud so that it bottoms. You don't want to thread the nut farther (by fully allowing the handles to open) as it becomes too difficult to collapse the nut within the frame. Then push the tool with threaded blind nut up into the 3/8" (9.5MM) hole which has been prepared. Make sure you have it positioned straight and squeeze the handles hard. You will be able to feel the nut collapse inside the frame but it may not have collapsed completely as you did not squeeze the handles for a long distance. Back off on the blind nut thumb turn several turns (while slackening pressure on the handles) and this will give you an opportunity to squeeze again. It's a ratchet effect. When you can no longer squeeze the handles, the nut is fully collapsed. Remove the tool from the collapsed nut by turning the blind nut thumb turn **counterclockwise** so as to remove the threaded stud from the nut.

With the nuts having been collapsed, the rest of the installation proceeds as is described in the Magnalock manual.

#### **4. ADDITIONAL TOOLS/PARTS**

The kit also contains a T handle allen wrench of the correct size for tightening Magnalock mounting screws and the strike mounting screw. The other items are additional fasteners to the ones supplied with the Magnalock (in case of misplacement), and other useful fastener type items which are sometimes needed when the Magnalock is to be mounted in an unusual situation. "Refills" for all of these items are available from Securitron (see factory catalog).

#### **5. RECOMMENDED TOOLS NOT IN THE INSTALLATION KIT**

The following tools are not included in kit for reasons of wide availability and/or cost but we recommend that you employ them.

**A battery operated drill** is the most productive way to drill your holes and rapidly install your mounting screws. The absence of a power cord enhances safety as the risk of someone tripping is lessened and in new construction, it can be awkward to bring AC power to the door.

**A spring loaded center punch** marks your holes for drilling quickly and accurately and reduces the risk of the drill bit "walking".

**Bullet Point drill bits** (Black and Decker) are widely available at Home Depot stores and other outlets. They are costly but include a small diameter pilot bit in the center of the finished diameter (3/8" or 1/2") bit. This allows faster work as no separate pilot hole need be drilled but more importantly, bullet point bits yield a rounder hole with reduced burrs which works better with Securitron blind nuts. We urge you to try these bits and expect that you will find broad use for them.