

INSTALLATION AND OPERATING INSTRUCTIONS For Model M38 and M68 Magnalocks (Versions "L", "S" and "LS" with "D" and "T" Options)

1. INTRODUCTION

Securitron's Model M38 and M68 Magnalocks are fail safe electromagnetic locks designed for *interior use in areas which require controlled access or egress. Each unit includes an interlocking mounting bracket and a power and control wiring access compartment which provides the added convenience of wiring "at-the-lock". The sleek, low-profile design provides a professional looking, unobtrusive integration into a wide range of architectural applications and can be easily retrofitted to replace existing magnetic lock systems.

* M38 and M68 Magnalocks are not designed, recommended or approved for exterior (outdoor) use. Interior use is described as any door installation to the interior of a building (i.e. offices, work or storage rooms) or to the interior side of any perimeter exterior door.

2. SPECIFICATIONS

M38:

Holding Force: 600 Lbs. [272 Kg]
Dimensions:
Inches: 10-1/2"L X 2-9/16"H X 1-9/16"D
Millimeters: 267 L X 65 H X 40 D
Electrical:
12 Volts DC:
Current Requirement: 300 – 325 mA
Power Consumption: 3.6 Watts
24 Volts DC:
Current Requirement: 150 – 175 mA
Power Consumption: 3.6 Watts

M68:

Holding Force: 1,200 Lbs. [544 Kg]
Dimensions:
Inches: 10-1/2"L X 3-5/8"H X 1-13/16"D
Millimeters: 267 L X 92 H X 46 D
Electrical:
12 Volts DC:
Current Requirement: 250 – 275 mA
Power Consumption: 3.0 Watts
24 Volts DC:
Current Requirement: 125 -150 mA
Power Consumption: 3.0 Watts

3. PRODUCT OVERVIEW

Upon unpacking this product, an inventory should be made to ensure that all the required components and hardware have been included. Along with these instructions and the installation template, the lock assembly (M38 Shown) should include the following items:



4. RECOMMENDED TOOLS

- | | |
|--|--|
| Hammer | Wrench, 1/2" box-end |
| Center punch | Pliers, vise grip |
| Drill motor | Screwdrivers: #1 and #3 Phillips |
| Drill bits: 3/16", 7/32" 3/8" and 1/2" | Hex (Allen) wrenches: 1/16" (provided) & 3/16" |

5. INSTALLATION INSTRUCTIONS

5.1. Pre-Installation Survey

Due to the variety of mounting configurations available with this product, it is strongly recommended that an initial survey and assessment be made of the physical area to which the Magnalock will be installed. A determination of the optimal method of mounting should be made prior to installation with considerations made to the following:

- A. Physical strength of mounting area. The structural integrity of mounting surfaces must be strong enough to meet or exceed the holding force of the Magnalock.
- B. Protection of the lock from external attack. The Magnalock and the wiring must be protected to a reasonable degree from potential damage due to intruders or vandals.
- C. Convenience and accessibility of area to be protected. The Magnalock assembly should be installed in a location that will not hinder or create a potential safety hazard to authorized personnel routinely accessing the protected area.

The mounting configuration addressed in detail in this manual will be for an outswinging door. All hardware required for the outswinging mount configuration has been included with this unit. For the inswinging version of mounting, a bracket accessory Top Jam Kit (TJ-38 or TJ-68 Series) is required. Both kits are available through Securitron. The following illustrations show two basic mounting configurations:

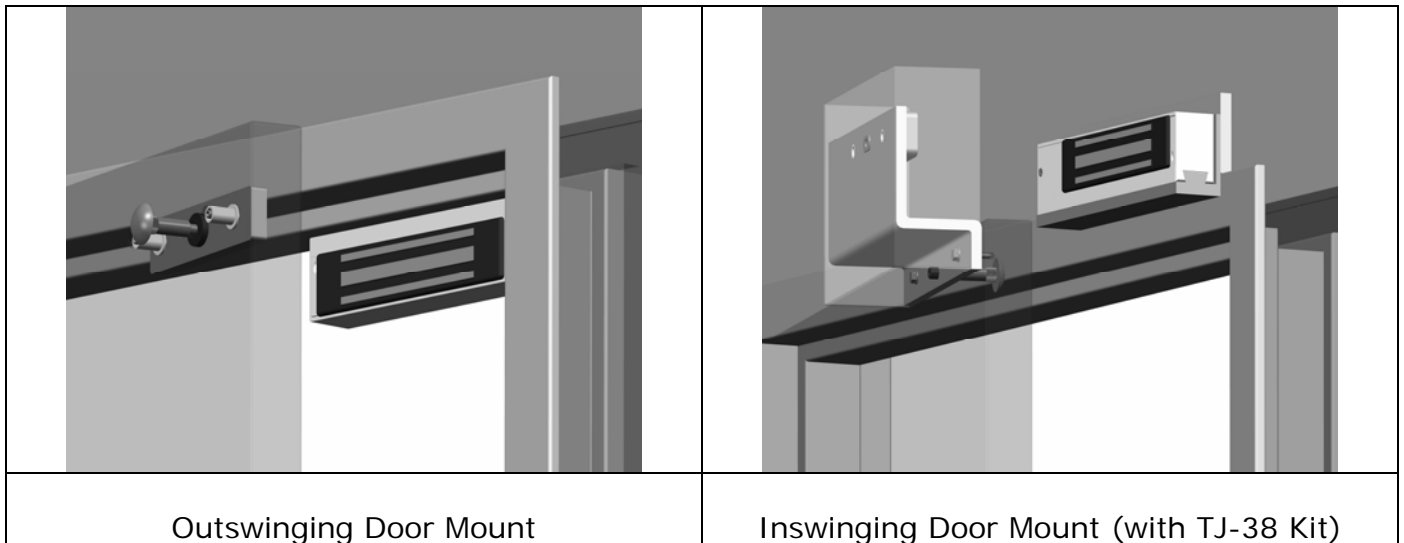

The Magnalock should normally be mounted under the door frame header in the corner furthest from the hinges. Most commonly the lock is positioned horizontally but vertical orientation may also be considered. In some cases for example, the horizontal header on an aluminum frame glass door is not as strong as the vertical extrusion, so vertical mounting would obviously be preferred. This (outswinging) type of installation places the Magnalock on the opposite side of the door as the door swings away from the lock. This configuration should be used for all facility exit doors (otherwise the lock would be located on the outside of the building). For interior doors, it is also recommended that the lock be mounted in this manner unless security planning anticipates a physical assault on the lock from that side of the door in which case the inswinging mounting kit (TJ-38 or TJ-68) should be obtained from Securitron.

5.2. Door Lock Installation

Figure 1 below is a typical cross section view of an M38 installed to a metal door frame in the outswinging door mount configuration:

Note: Reference dimensions are in parenthesis – see the product mounting template for clarification.

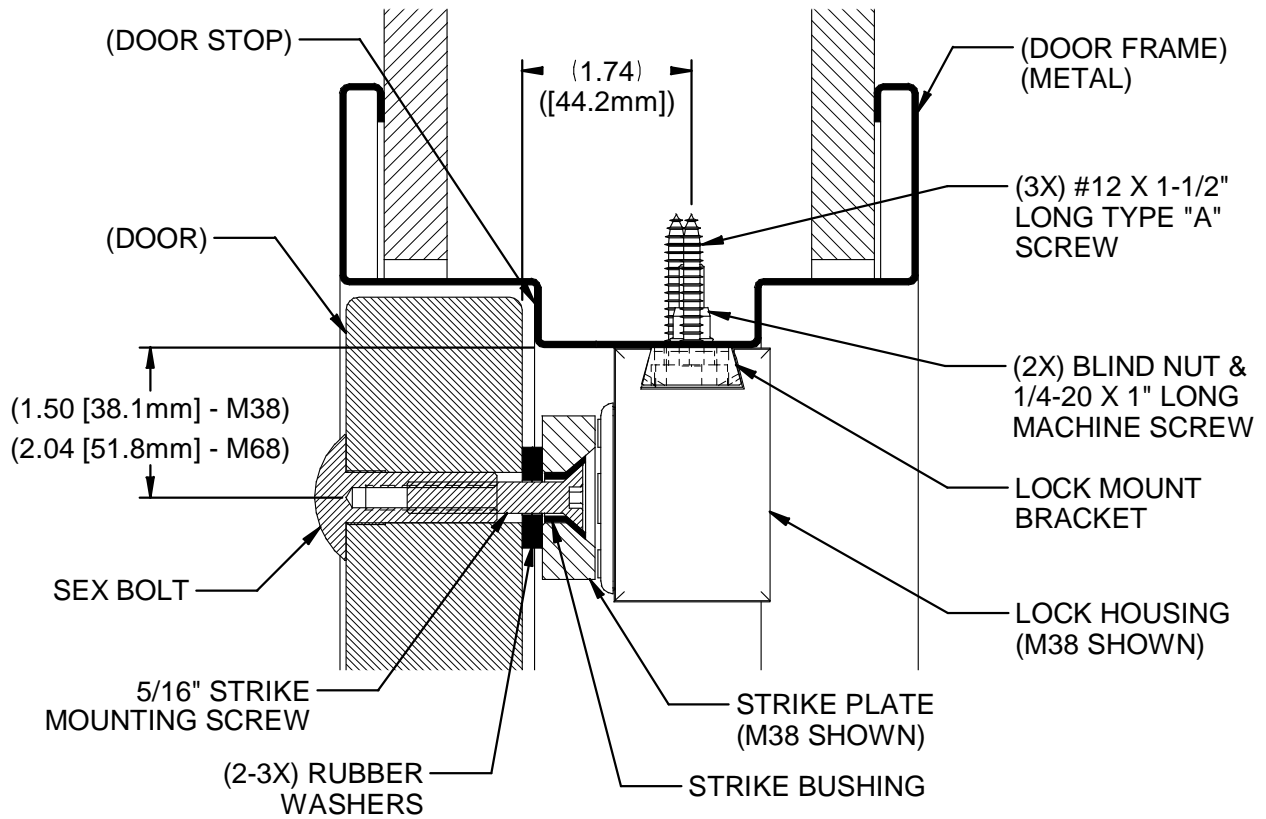

Figure 1

5.2.1. Door Preparation

Figure 2 below is an exploded illustration of the assembly of the strike to the door:

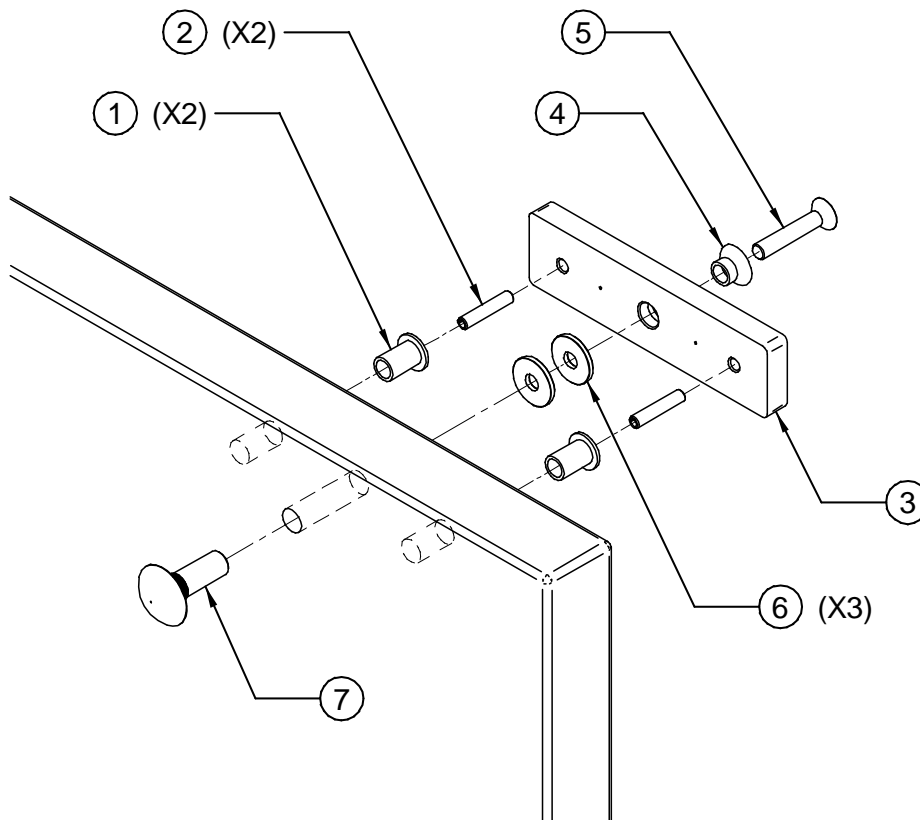

Figure 2

ITEM	QTY	PART NUMBER	NOMENCLATURE/DESCRIPTION
1	2	560-12050	Strike Roll Pin Bushing, Clear, Nylon
2	2	330-10800	Roll Pin, 1/4" X 1-1/4" Long, Steel (Z/P)
3	1	380-30300 775-60400	Strike Plate, M32/M38 (shown) Strike Plate, M62/M68
4	1	330-12000	Strike Mounting Bushing, White, Delrin
5	1	300-13600	Socket Flat Head Screw, 5/16-18 UNC X 1-3/4" Long, Steel (Z/P)
6	3	310-11100	Washer, 1" O.D. X 11/32" I.D. X 1/8" Thick, Neoprene
7	1	330-12600	Sex Bolt, 5/16-18 UNC X 1-1/2" Deep, Steel (Z/P)

5.2.1.1. Strike Installation

Using **Figure 2**, the template provided and the following step-by-step installation instructions, complete the installation of the strike into the door.

1. Fold the template and place into position on door/frame at desired mounting location. Mark the strike center hole on the door and the center position of the two (2) slotted mounting bracket holes on the door frame.
2. Drill one (1) 3/8" [9.5mm] diameter hole through door (at mark for strike center hole), then drill 1/2" [12.7mm] diameter through door from opposite side for sex bolt (**Item #7**).
3. From the side of the door that the strike will be mounted, drill two (2) 1/2" [12.7mm] diameter X 1-3/8" [34.9mm] deep holes for the roll pin bushings (**Item #1**).
4. Insert the two (2) strike roll pin bushings into the holes in the door (either side of strike center hole).
5. Obtain the strike (**Item #3**) and place on a clean, flat surface. Using a hammer, insert and **lightly** tap to install the two (2) roll pins (**Item #2**) into the two (2) 1/4" [6.4mm] diameter recesses of the strike. **Note:** Care should be taken when installing roll pins into the strike. Excessive impact to the strike or over-driving the pins into the recesses may distort the contact surface of the strike which will affect the holding force of the lock.
6. Insert the strike mounting bushing (**Item #4**) and the 5/16-18 UNC X 1-3/4" long socket flat head screw (**Item #5**) through the center hole of the strike.
7. Install two (2) of the neoprene washers (**Item #6**) over the screw on the opposite side (roll pin side) of the strike. **Note:** A third washer is provided but is normally not used. It may be used however, if required to take up any additional spacing that cannot be taken up by adjusting the lock mount bracket.
8. Insert the strike mounting screw (with washers) into the 1/2" [12.7mm] diameter strike center hole in the door while aligning the roll pins of the strike assembly into the roll pin bushings.
9. Start the sex bolt (**Item #7**) into the 1/2" [12.7mm] diameter hole from the opposite side of the door. **Do not** fully seat the sex bolt against the surface of the door at this time, but thread the sex bolt onto the end of the strike mounting screw. Using a 3/16" hex wrench, continue to thread the strike mounting screw into the sex bolt while ensuring that the assembly maintains a straight (perpendicular) alignment to the door.
10. Using a hammer and a 3/16" hex wrench, gradually tighten the screw into the sex bolt until it is snug, and then tap the head of the sex bolt toward the face of the door. Keep repeating this procedure to slowly "walk" the sex bolt into place (head against door face) – this ensures a straight (perpendicular) alignment of the strike assembly to the door. **Note: Do not over tighten.** When the strike is fully installed there should be some play or flexing of the strike around the washers. This allows the lock to pull the strike into the correct alignment for maximum holding force.

5.2.2. Door Frame Preparation

Figure 3 below is an exploded illustration of the assembly of the lock to a metal door frame:

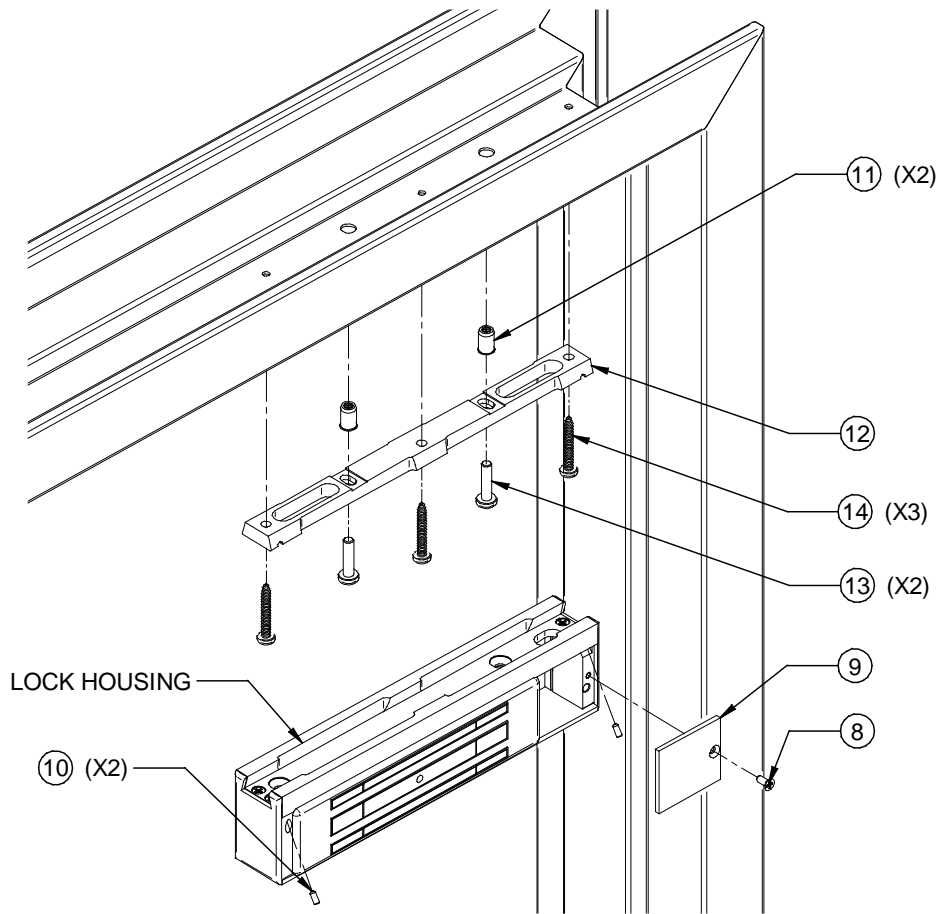

Figure 3

Figure 4 below is an exploded illustration of the assembly of the lock to a wood door frame:

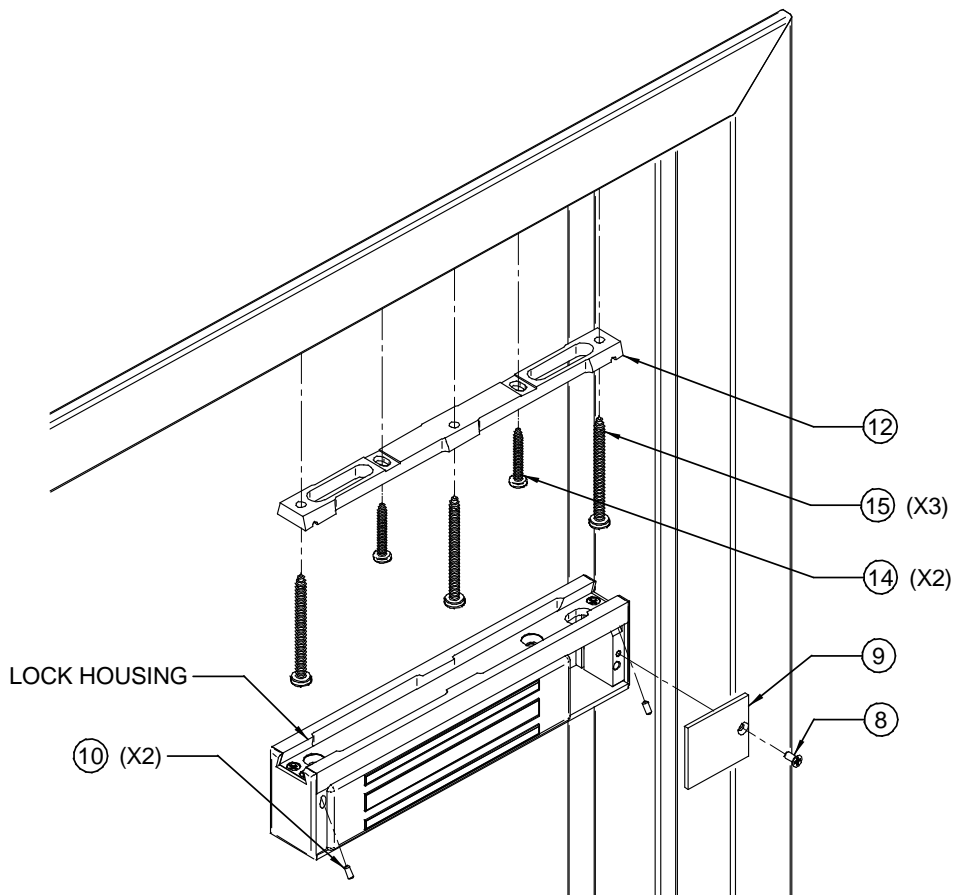

Figure 4

ITEM	QTY	PART NUMBER	NOMENCLATURE/DESCRIPTION
8	1	(Included)	Phillips Flat Head Screw, 8-32 UNC
9	1	(Included)	Lock Housing Front Cover
10	2	(Included)	Socket Set Screw, 6-32 UNC
11	2	320-10800	Blind Nut, 1/4-20 UNC, 1-Piece
12	1	(Included)	Standard Mounting Bracket
13	2	300-12403	Phillips Pan Head Screw, 1/4-20 UNC X 1" Long, Steel (Z/P)
14	3	300-13010	Phillips Pan Head Screw, #12 X 1-1/2" Long, Type "A", Steel (Z/P)
15	3	300-13110	Phillips Pan Head Screw, #14 X 3" Long, Type "A", Steel (Z/P)

5.2.2.1. Lock Installation

Using **Figure 3** (for metal door frames) or **Figure 4** (for wood door frames) above, the template provided and the following step-by-step installation instructions, complete the installation of the lock onto the door frame.

1. Locate the two (2) marks applied to the door frame for the mounting bracket using the template in the previous strike installation section (Section 5.2.1.1, Step 1), then:
 - a. **For Metal Door Frame:** Drill two (2) 3/8" [9.5mm] diameter holes through the door frame at these locations.
 - i. Install blind nuts (**Item #11**) into the 3/8" [9.5mm] diameter holes in the door frame as follows:
 1. Using blind nut collapsing tool provided (with blind nut in place), insert the end of the blind nut into the hole.
 2. Using a hammer (if necessary) tap the nut in until the upper lip seats against the door frame surface.
 3. While holding the hex portion of the collapsing tool with a 1/2" box-end wrench or vise grip pliers, turn the socket head cap screw of the tool using a 3/16" hex wrench. **Note:** Maintain firm pressure toward the door frame mounting surface while collapsing the nut.
 4. Once the blind nut is adequately collapsed, remove the tool from the nut by backing the cap screw out of the blind nut thread.
 5. Install the second blind nut onto the collapsing tool (cap screw) and repeat sub-steps i1 through i4.
 - b. **For Wood Door Frame:** Drill two (2) 3/16" [4.8mm] diameter holes X 1-1/4" [31.8mm] deep (minimum) into the door frame at these locations.
 2. Remove the mounting bracket (**Item #12**) from the top (dovetail) area of the lock housing as follows:
 - a. Using a #1 Phillips screwdriver, remove the 8-32 UNC flat head screw (**Item #8**) holding the lock housing front cover (**Item #9**) in place. Remove cover and set screw and cover aside for later assembly.
 - b. Using a 1/16" hex wrench, back the two (2) 6-32 UNC socket set screws (**Item #10**) out far enough to allow free (sliding) movement of the mounting bracket. **Note:** It is not necessary to completely remove the set screws to allow removal of the bracket – **five (5) 360-degree counterclockwise turns** is normally far enough.
 - c. Slide the bracket far enough to disengage the bracket from the top of the lock housing. **Note:** The bracket/lock interface can be disengaged by moving the lock (or bracket) 1" to 2" [25-50mm] laterally to one side or the other, then withdrawing away vertically – you do not have to slide the lock or bracket the full length of the housing to remove or install.
 3. Place the mounting bracket onto the frame aligning the two (2) slotted holes in the bracket with the previously installed blind nuts (for metal frame) or drilled holes (for wood frame). Using a #3 Phillips screwdriver, lightly secure the mounting bracket to the frame with:

- a. **For Metal Door Frame:** Two (2) 1/4"-20 UNC X 1" long Phillips pan head screws (**Item #13**) provided.
 - b. **For Wood Door Frame:** Two (2) #12 X 1-1/2" long Phillips pan head type "A" screws (**Item #14**) provided.
Note: Do not fully secure (tighten) the screws at this point. Tighten screws to "snug" and back out as necessary to provide slight movement of bracket for adjustment.
4. Assemble the lock housing to the bracket by inserting and engaging the top (dovetail) feature of the lock with the mounting bracket. Slide the lock into proper position (centered on the mounting bracket).
 5. Adjust the lock/bracket assembly in the slots of the bracket as necessary to establish proper relationship with (against) the strike.
 6. Carefully remove the lock housing from the mounting bracket while attempting not to alter the position of the bracket on the door frame.
 7. Using a #3 Phillips screwdriver, fully secure the two (2) screws (**Item #13 or #14**) installed in Step 3 above.
 8. Using the installed mounting bracket as a guide, locate and drill three (3) holes into the door frame corresponding to the remaining three (3) open holes in the bracket:
 - a. **For Metal Door Frame:** Drill three (3) 3/16" [4.8mm] diameter holes (through).
 - b. **For Wood Door Frame:** Drill three (3) 7/32" [5.6mm] diameter holes X 2-3/4" [69.9mm] deep (minimum).
 9. Using a #3 Phillips screwdriver, install the three (3) #12 screws (**Item #14** for metal frame) **or** #14 screws (**Item #15** for wood frame) through the bracket and into the holes in the door frame. Tighten the screws to secure the mounting bracket to the door frame.
 10. Determine optimal location then drill a 3/8" [9.5mm] diameter hole through the door frame for the lock power cable. **Note:** This hole must align within the large slotted "window" in the top of the lock housing when the lock is installed on the mounting bracket.
 11. After all electrical wiring has been completed, install the housing front cover (**Item #9**) and secure in place using the 8-32 UNC flat head screw (**Item #8**).

5.3. Lock with "D" (Door Position) Option - Installation

For locks provided with the "D" (Door Position) option, the magnetic (reed) switch is factory installed inside the control wiring access compartment cover.

When a lock has been previously installed and it has been later determined to upgrade to the "D" option in the field, the template provided in the upgrade kit illustrates proper location and installation of the switch to the inside of the compartment access cover.

Using **Figure 5** below, the template provided and the following step-by-step installation instructions complete the installation of the actuator block to the door adjacent to the strike plate.

1. After marking the mounting holes for the actuator block on the door using the mounting template provided with the lock (or upgrade kit), center punch these locations. The actuator block has hardware included for mounting in two types of configurations. Decide which of the following choices will work best for the application and then:
 - a. **If Mounting Using #8 Flat Head Screws (Recommended for Solid Core (Wood), Aluminum Frame or Hollow Metal Doors):** Drill two (2) 9/64" [3.6mm] diameter holes X 3/4" [19.1mm] deep (maximum) into the door at the center punched locations or;
 - b. **If Mounting Using #6 Pan Head Screws (Recommended for Aluminum Frame, Hollow Metal or the Top Jam Z-Bracket):** Drill two (2) 1/8" [3.2mm] diameter holes X 3/8" [9.5mm] deep (maximum) into the door at these locations.

2. Using a #1 Phillips screwdriver and the screws provided secure the actuator block to the door making sure that the **arrow of the label** on the backside of the block is **facing toward the mounting edge of the lock**.

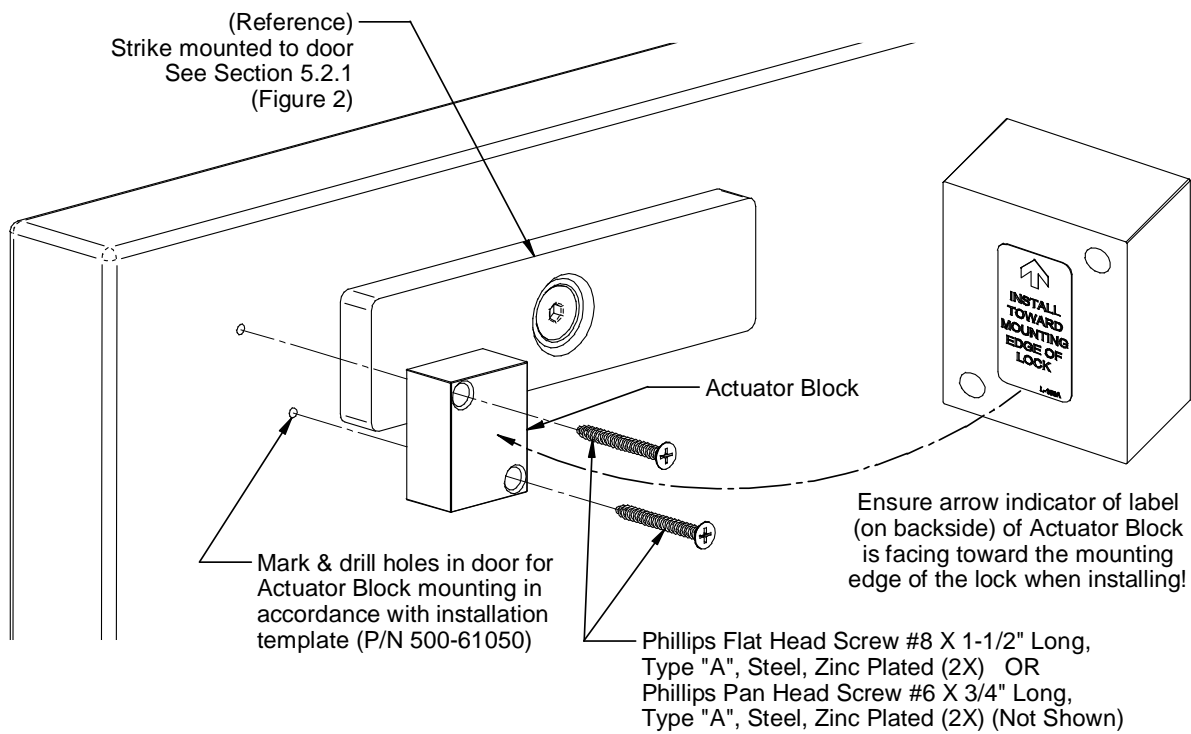

Figure 5

5.4. Inswinging Door Lock Installation

As previously mentioned, additional hardware and brackets are required for mounting the lock system in the inswinging door configuration. The brackets, hardware and instructions required for the installation of the lock in this arrangement are available in a Top Jam Kit (TJ-38 or TJ-68 Series) which may be obtained through Securitron Magnalock Corporation or one of our authorized representatives.

6. OPERATIONAL INSTRUCTIONS

The M38/68 series Magnalocks are direct holding fail safe electromagnetic locks. Both incorporate Securitron's unique dual voltage system. Simply apply 12 or 24 volts DC observing polarity (See **Figure 6**) and the locks will energize to their respective holding forces of 600 lbs. [272 Kg] for the M38 and 1200 lbs. [544 Kg] for the M68.

The **"L"** option adds the ability to visually inspect the lock and determine via a red LED that the lock is in fact energized.

The addition of the **"S"** option provides a lock status sensing signal which indicates that the lock is secure and gives you the added ability of a SPDT dry contact that you can interface to either the access control system or intrusion detection system (See **Figure 7**). The **"S"** option will only report the door is secure if two criteria are met. One - the lock must be powered and two - the strike armature must be in full unobstructed contact with the lock face.

Add the two options together **"LS"** and get both the dry contact output and a visual reference via a bi-color LED (red = door powered and locked, green = door powered but not locked and off = door not powered or locked).

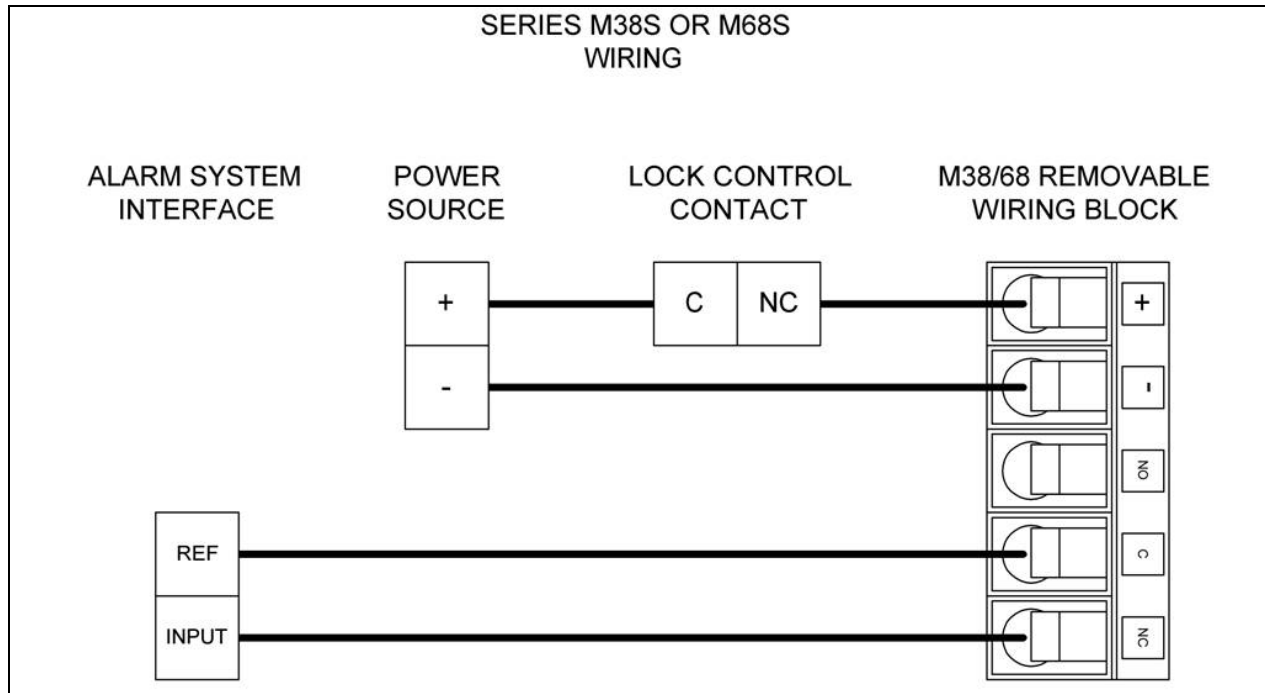
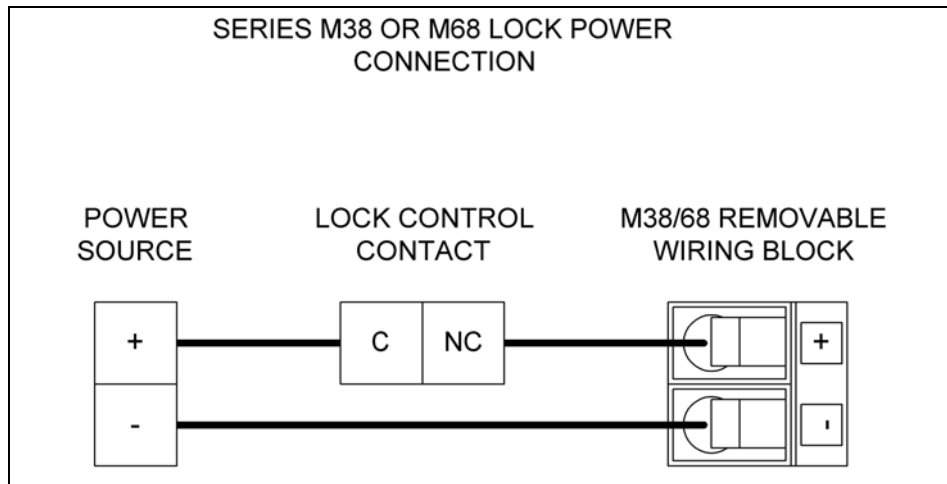

The addition of the **"D"** option incorporates a door position sensing switch which indicates when the door is outside of the sensing range of the lock (3/8"-3/4") and provides the added ability of a SPDT dry contact that can be interfaced with either an access control system or intrusion detection system (See **Figure 8**). The **"D"** option will report the door position whether the lock is powered (secured) or not.

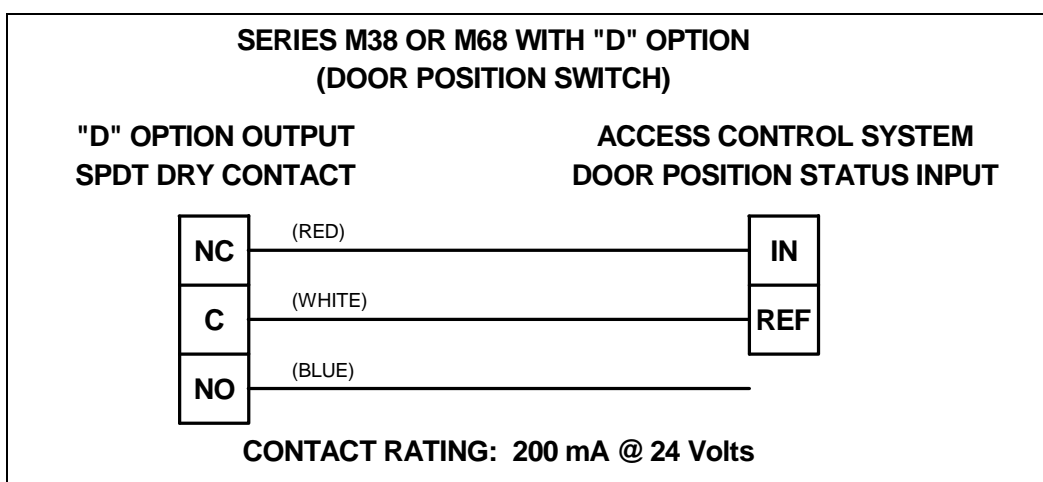

The **"T"** suffix option implements a small micro switch to create a tamper resistant enclosure of the control wiring access compartment. At approximately .03" movement of the access cover away from the lock housing (usually less than a full turn of the mounting screw) a signal is transmitted to indicate that access is being attempted to the lock control wiring compartment. (See **Figure 9** for wiring diagram).

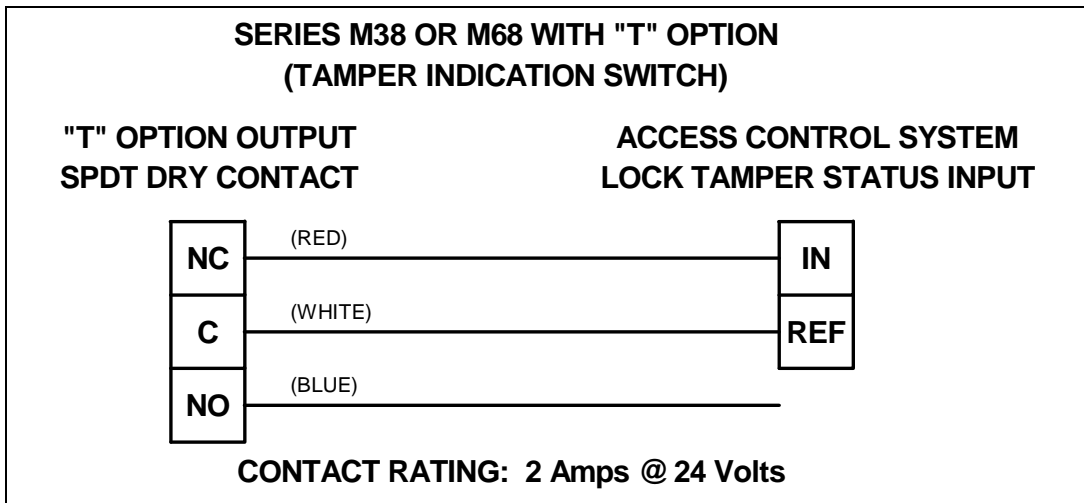

Figure 9

The **"OS"** suffix option available for M68 series locks provides a modified "Offset" strike to shift the strike contact face 1/4" [6.4mm] further away from the door frame stop than the standard strike. This can be helpful in the installation to aluminum frame glass doors where the height of the aluminum rail at the top of the door is not sufficiently wide enough to accommodate the standard sex bolt/strike installation. It should be noted that an approximate 10% loss in holding force results from the use of this strike because of its offset position however, this should not be significant in that aluminum frame glass doors are not high security barriers. The offset strike is included with locks ordered with the **"OS"** suffix or may be ordered separately.

A "Split Strike" configuration option is available for M68 series locks ordered with the **"SS"** suffix. This allows one lock to be used to secure two doors in a double door configuration. In this method, a single Magnalock is mounted near the center of the header and a half size strike is provided for mounting to each door/leaf. This arrangement will also reduce the holding force to about 550 Lbs. (250Kg) per door/leaf. Locks ordered with the **"SS"** suffix include the two (split) strikes or they may be supplied separately.

7. MAINTENANCE

To keep the Magnalock in top working order, especially a Magnalock equipped with the **"S"** (Senstat) option, we recommend taking a clean cloth and rubbing alcohol or a non-abrasive cleaner and wiping down the face of the Magnalock and the strike once every six months.

8. APPENDICES

A. WIRE GAUGE SIZING

If the power supply is distant from the lock, voltage will be lost (dropped) in the connecting wires so that the Magnalock will not receive full voltage. The following chart shows the minimum wire gauge that will hold voltage drop to an acceptable 5% for different lock to power supply distances. Proper use of the chart assumes a dedicated pair of wires to power each Magnalock (no common negative). Note that a Magnalock operating on 24 volts is a much better choice for long wire runs as it has 4 times the resistance of a 12 volt installation. Also note that the correct calculation of wire sizing is a very important issue as the installer is responsible to insure that adequate voltage is supplied to any load. In multiple device installations, the calculation can become quite complex so refer to the following section "Calculating Wire Gauge Sizing" for a more complete discussion.

Distance	Gauge 12V	Gauge 24V	Distance	Gauge 12V	Gauge 24V
100 FT	24 GA	24 GA	800 FT	18 GA	22 GA
200 FT	22 GA	24 GA	1500 FT	14 GA	18 GA
400 FT	20 GA	22 GA	2000 FT	14 GA	18 GA

CALCULATING WIRE GAUGE SIZING

The general practice of wire sizing in a DC circuit is to avoid causing voltage drops in connecting wires that reduce the voltage available to operate the device. As Magnalocks are very low power devices, they can be operated long distances from their power source. For any job that includes long wire runs, the installer must be able to calculate the correct gauge of wire to avoid excessive voltage drops.

This is done by taking the current draw of the lock and multiplying by the resistance of the wire $I \times R = \text{Voltage drop}$ (i.e. $0.100A \times 10.1 \text{ Ohms} = 1.01 \text{ Volts}$ dropped across the wire). For all intents and purposes it can be said that a 5% drop in voltage is acceptable so if this were a 24 Volt system ($24 \text{ Volts} \times .05 = 1.2 \text{ Volts}$) a 1.01 Volt drop would be within tolerance.

To calculate the wire resistance, you need to know the distance from the power supply to the Magnalock and the gauge (thickness) of the wire. The following chart shows wire resistance per 1000 ft (305 meters):

Wire Gauge	Resistance/1,000 ft	Wire Gauge	Resistance/1,000 ft
8 Gauge	.6 Ohms	16 Gauge	4.1 Ohms
10 Gauge	1.0 Ohms	18 Gauge	6.4 Ohms
12 Gauge	1.6 Ohms	20 Gauge	10.1 Ohms
14 Gauge	2.5 Ohms	22 Gauge	16.0 Ohms

B. CONSIDERATIONS FOR MAXIMUM PHYSICAL SECURITY

M38 and M68 Magnalocks carry rated holding forces of 600 lbs. [272 Kg] and 1,200 lbs. [544 Kg] respectively. There are several installation and application variables to be considered which affect the security level that may be obtained while using a Magnalock.

In the case of wooden doors (other than solid hardwoods), aluminum frame glass doors, and hollow metal doors, the M38 should be employed in a "traffic control" mode. This is because a determined assault on these types of door/lock configurations has the potential of "popping" this model open. The M68 is generally stronger than the door itself. Users have logged periodic cases of an assault where the door has been destroyed leaving the Magnalock intact and still retaining the piece of the door where the strike was mounted.

A pry bar may be used to try to pry the door open. However, what generally occurs is that the door will experience material failure. The pry bar tears (in the case of wood) or bends (metal) the door material without defeating the lock. The general fact that a Magnalock mounts on the other side of the door from the attacker is an important contributor to its strong resistance to assault.

The concept of preferring a door that gives also affects the issue of physical security on different door types. Oddly enough, the characteristics that make an inswinging door strong

can make it more difficult to secure if it is stiff or rigid. Steel doors and most particularly solid steel doors such as may be found in prisons, transmit impact much more effectively to the lock and as such may be defeated by repeated leg blows or by charging the door. If the end user has such doors and/or a security environment where such determined attacks can be foreseen on the doors, it is his responsibility to ensure that the Magnalock's strength is adequate for the application. Selection of the model 68 is strongly recommended with another technique being the use of multiple locks.

These Magnalocks have been carefully designed to be installed with the included fasteners which substantially exceed the strength of the lock. If the installer substitutes for any of the factory included fasteners or hardware for any reason, the strength capability of the installation may be compromised. It should be noted that a key component to the successful installation of this product is the sex bolt. The head of the sex bolt is the only part of the lock assembly that is accessible to an attacker.

It is also vital when mounting the magnet (lock housing) into a metal frame to use the included machine screws and steel blind nuts. An alternative technique has been to use sheet metal screws which some installers feel is easier. This is extremely ill advised as the magnet receives a torquing force each time that the door is closed, which over time will work the sheet metal screws loose. It has been determined that sheet metal screws may be considered acceptable, although not preferred, if the frame header is made of steel. Indeed this is mandated when Securitron's concrete header bracket is utilized. On an aluminum header however, mounting with sheet metal screws is dangerous as the steel screw threads will eventually tear through the relatively soft aluminum.

To fully complete an installation that maximizes the effectiveness of the included fasteners, the thread locker compound (provided) should be used to prevent the threads from loosening over time.

C. TROUBLESHOOTING

PROBLEM: No magnetic attraction between magnet and strike plate.

First be sure the Magnalock is being correctly powered with DC voltage. This includes connecting the power wires with correct polarity. Positive must go to red and negative to black. If the magnet body is wired in reverse polarity, it will not be damaged, but it will not operate. If the unit continues to appear dead, it must be electrically checked with an Ammeter. It must be powered with the correct input voltage and checked to see if it draws the specified current. If the unit meters correctly, it is putting out the correct magnetic field and the problem must lie in the mounting of the strike.

PROBLEM: Reduced holding force.

This problem usually expresses itself in terms of being able to kick the door open or to open it with a shoulder. Check the strike and magnet face to see if some small obstruction is interfering with a flat fit. Even a small air gap can greatly reduce the holding force. Another possibility is if the strike plate has a dent on it from being dropped for example. Remove the strike from the door and try to rock it on the magnet face to insure that it is flat. If the strike and magnet are flat and clean, the cause is nearly always improper mounting of the strike in that the strike is mounted too rigidly. The strike **must** be allowed to float around the rubber washer stack which must be on the strike center mounting screw. The magnet then pulls it into flat alignment. To correct the problem, try loosening the strike mounting screw to see if the lock then holds properly. Another possibility is if you are operating the lock on AC instead of DC or on half wave rectified DC (transformer + single diode). Half wave rectified DC is unacceptable; you must at a minimum employ full wave rectified DC (transformer + bridge).

PROBLEM: The Senstat output does not report secure.

Because of the simplicity of Securitron's patented Senstat design, this is almost always a case of the lock status sensor doing its job. It is not reporting secure because a small obstruction or a too stiffly mounted strike is causing the Magnalock to hold at a reduced force. The problem is corrected by cleaning the surfaces of the magnet and strike (see Maintenance Section 7) or establishing proper play in the strike mounting. If this does not work, you can verify function of the Senstat feature as follows: Note that there are two (2) thin vertical lines on the magnet face that can be said to separate the core into three (3) sections from left to right. The Senstat output is created by the strike establishing electrical contact between the leftmost and rightmost core segments. With the lock powered, use a pair of scissors and press the points respectively into the leftmost and rightmost core segments. The Senstat output should then report secure. This shows that the problem lies in the strike not making correct flat contact with the magnet face. If the scissors technique does not cause the lock to report secure, check to see if there is a broken Senstat wire. If this is not the case, the lock must be returned to the factory for replacement.

PROBLEM: The lock does not release.

When power is removed from it, the Magnalock must release. Therefore the complaint of "lock will not release" is either mechanical bonding via vandalism or a failure to completely release power. By mechanical bonding, we simply mean that glue has been applied between the strike plate and magnet as a prank. Failure to completely release power is generally a wiring integrity problem. What happens is that an upstream switch removes power from the wires going to the Magnalock, but through an installation error, the wires have their insulation abraded between the switch and lock so that partial or full power can leak in from another Magnalock or other DC device with similarly abraded wiring. This is most likely to occur at the point where the wire cable leaves the Magnalock case and enters the door frame. Another area is via an improper splice on wiring in conduit. Either a metal door frame or the metal conduit is capable of leaking power between multiple devices with abraded wires, thereby bypassing switches. A good way to check this electrically (as opposed to visually removing and inspecting the wires) is to use a meter and check for leakage between the power supply positive or negative and the door frame and conduit. Magnalocks should be powered by isolated DC voltage without any earth ground reference to positive or negative.

PROBLEM: The lock rusts.

Both the magnet core and strike plate are plated and sealed following a military specification. If rusting appears, the most common cause is that improper cleaning (with steel wool for instance) has occurred and this has stripped off the relatively soft plating. Once the plating

has been removed, it cannot be restored in the field, so the lock will have to be periodically cleaned and coated with oil or other rust inhibitor. A rusty Magnalock will still function but at reduced holding force. If the product is installed in a heavily corrosive atmosphere, such as near the ocean, it will eventually rust even with non-abrasive cleaning. The only answer then becomes continued periodic removal of the rust.

PROBLEM: Apparent electronic noise interference with the access control system.

Electric locks, being inductive devices, return voltage spikes on their power wires and also emit microwave radiation when switched. This can interfere with access control electronics causing malfunctions. Access control contractors often employ installation techniques designed to isolate the access control electronics from the electric lock. These include separate circuits for the lock, shielded wiring and other techniques. These techniques will vary with the sensitivity of the access control system electronics and should, of course be followed. Note that Magnalocks include internal electronics which suppress both inductive kickback and radiation. They have been extensively tested and accepted by numerous access control manufacturers and have been used in thousands of installations without incident. An apparent noise problem is therefore usually not caused by the Magnalock. The access control equipment may be itself faulty or have been installed improperly. One problem can arise with the Magnalock. If the Senstat version is being used, the strike plate (which passes current) must be isolated from a metal door and frame. Securitron supplies insulating hardware to accomplish this but the hardware may not have been used or the strike may be scraping against the header for instance. Check for full isolation between the strike and the door frame (when the door is secured) with an Ohmmeter. The presence of lock voltage potential in the door frame can interfere with the ground reference of access control system data communication and therefore cause a problem.

**IF YOUR PROBLEM PERSISTS
CALL SECURITRON TOLL FREE
1-800-MAG-LOCK**

9. MAGNACARE® LIFETIME REPLACEMENT WARRANTY

For warranty information visit www.securitron.com/en/site/securitron/About/MagnaCare-Warranty/