

SAM2-24 Shear Aligning Magnalock®

600 lbs holding force,
shear aligning Magnalock

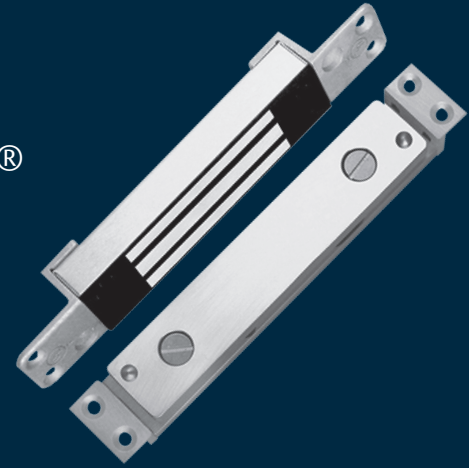

Hidden strength at any angle ideal for traffic control.

The compact and versatile SAM2-24 Shear Aligning Magnalock provides 600 lbs. of holding force to swinging or sliding doors. It is ideal for traffic control and to secure smaller applications, like sliding closet doors, atriums, and more. The SAM2-24 mounts fully concealed into wood, steel, aluminum or Herculite doors in any position: at the header, door edge or threshold.

Features

Standard Features

- Efficient, low power usage
- Fully sealed for weather resistant operations
- Compact design fits tight spaces
- Rust resistant—all ferrous metal surfaces plated for durability
- Instant release circuit —no residual magnetism
- Noise suppression with included MOV
- Recessed for aesthetically appealing finish
- 6 ft [1.83m] of jacketed, stranded conductor cable
- Direct mount in door frame for strength and reliability
- MagnaCare® lifetime replacement, no-fault, no questions asked warranty

Optional Features

- C Bond sensor



Grade 3



MagnaCare
Warranty



Fire Rated



Preload

Specifications

Certifications

- UL 10C Listed
- CAN4-S104, CAN/ULC-S533 Listed
- ANSI/UL 294 Listed
- ANSI/BHMA A156.23, Grade 3; E08571-1000, E08581-500 Compliant
- CSFM—California State Fire Marshal Approved

Electrical

- 84 mA at 24 VDC

Holding Force

- 600 lbs [272kg]

Operating Temperature

- -40° to 140°F [-40° to 60°C]
- Indoor or outdoor use
- Not for use in open channel doors

Shipping Weight

- 2.5 lbs [1.13kg]

Dimensions

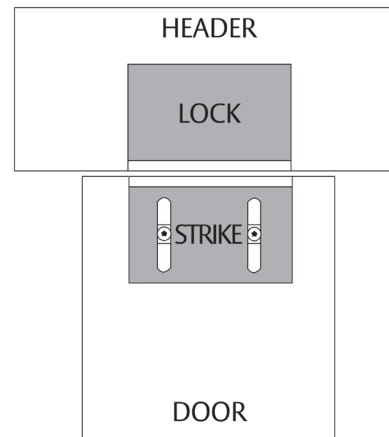
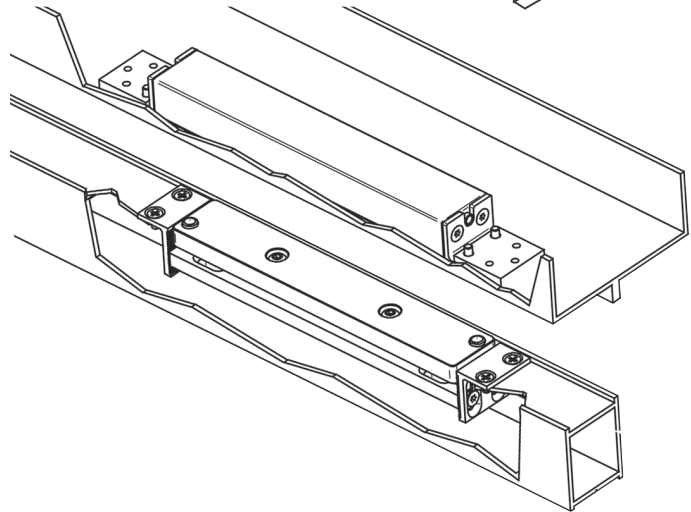
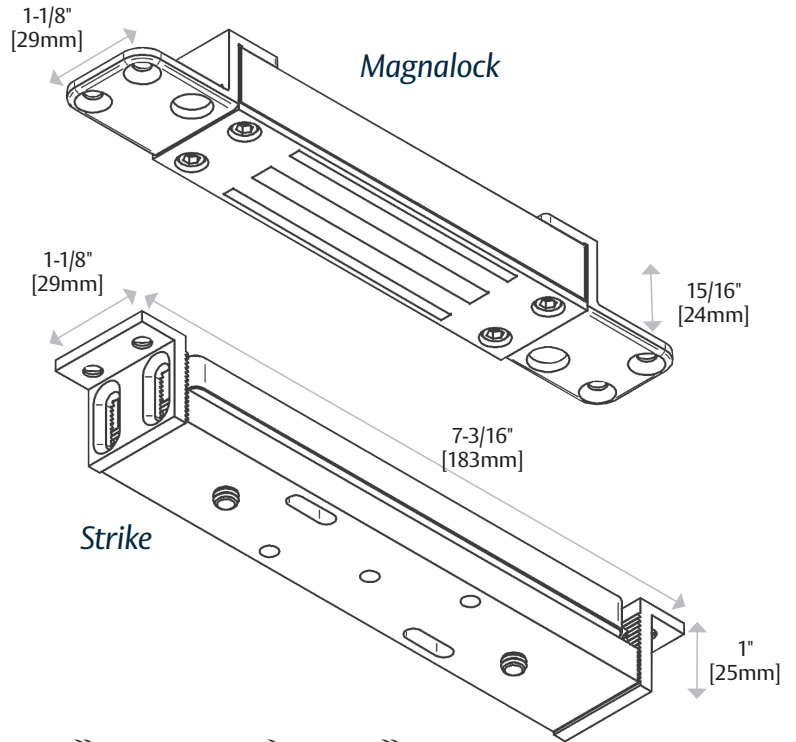

How to Order

MODEL SERIES	MONITORING OPTIONS	VOLTAGE
SAM2	C	- 24
SAM2	(blank) No Monitoring	24 VDC only
	C Bond Sensor	

SAM Accessories

SWB SAM Wood Bracket

- SAM Wood Door Bracket provides additional strength and protection for the SAM strike plate in wood door applications
- MagnaCare® lifetime replacement, no-fault, no questions asked warranty

PART NUMBER	DESCRIPTION	FINISH
SWB-03	SAM Wood Bracket	Brass Polished
SWB-10B	SAM Wood Bracket	Oil Rubbed Bronze
SWB-26D	SAM Wood Bracket	Satin Stainless

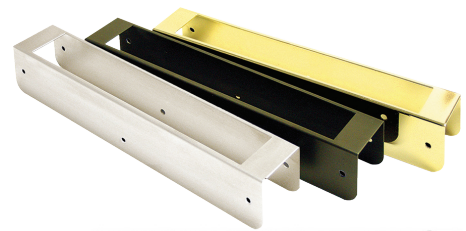

Dimensions

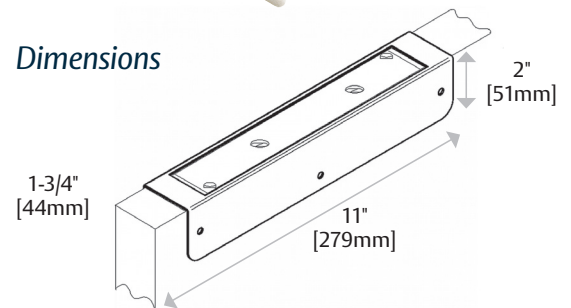

SAM Surface Mount Kit

- Available for the M38 and M68
- Used to mount the lock on the secure side of a door that swings into a secured area
- Includes a Z-Bracket and an oversized Dress Cover
- MagnaCare® lifetime replacement, no-fault, no questions asked warranty

PART NUMBER	DESCRIPTION	FINISH
SMLS	Surface Mount Housing Lock	Satin Stainless
SMSS	Surface Mount Housing Strike	Satin Stainless

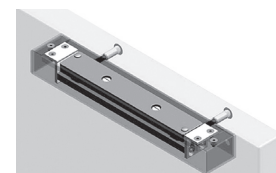

SMSS



MagnaCare
Warranty